



GREEN APPLE
AWARD WINNER



Exclusively
Curved Stairlifts



Platinum Stairlifts

Platinum Stairlifts is a company with many years experience in designing and manufacturing lifts for curved staircases.



The Platinum Headquarters are located in a modern purpose built factory on the edge of the Yorkshire Dales, it is home to our team of engineers, designers, customer services, helpline and training facility. We are proud of our reputation for dedication, commitment, quality and service, which is acknowledged by many as being the benchmark in the industry .

At Platinum we care about the needs of our customers. We are confident our products and services can make a real difference in making life easier and allowing you to retain or regain independence in your own home.

Please take time to familiarise yourself with the Platinum Curve and find out why Platinum is so often the first choice for curved stairlifts.

Exclusively Curved

Many other companies make a confusing number of differing lift styles, at Platinum we prefer to concentrate our expertise and resources on just one – **The Platinum Curve**.

We believe that by specialising in the design, manufacture and delivery of the domestic curved stairlift we can provide our customers with a superior product.

So, if your staircase requires a lift which needs to negotiate landings and corners, you can be assured that the Platinum Curve was designed and built with you and your home in mind.





Making your house adjust to you

At Platinum we understand that fitting a stairlift is a simple way of regaining full use of your home and can help you to remain independent within familiar surroundings.

We also appreciate that homes come in many shapes and sizes, this is why the Platinum Curve has been specifically designed to be very versatile and capable of fitting unobtrusively to almost any curved staircase. In the vast majority of cases Platinum Stairlifts are fitted to the stair-treads rather than the wall, so there is no building mess or damage to your décor.

A stairlift is a functioning appliance, but that does not mean it needs to look industrial. The Platinum Curve has been designed as a piece of modern furniture and to be as aesthetically pleasing as possible. This, coupled with a smooth and quiet operation makes it an attractive addition to any household. When not in use the Platinum Curve can be folded away and with its slim profile will not obstruct the stairway for use by other people. Should you wish, our trained advisors will visit your home by appointment. They will survey your staircase and assess the most appropriate solution for your specific needs and circumstances.

Comfort and Safety

There are many different requirements for people who need a stairlift, invariably comfort and safety are high on the list.

The Platinum Curve incorporates a PMDC motor to ensure a smooth and gentle ride and the twin rail mechanical levelling system provides for gentler and steadier travel on turns and corners. In addition the seat is ergonomically styled and incorporates plump padding and cushioning.

For safety the lift comes with a retractable, car style seatbelt as standard and the seat can swivel making it easier for users to get off at the top of the stairs. For safety, the footrest and carriage incorporates a number of pressure sensitive safety edges which stop the lift instantly should it come into contact with any obstructions. The motor has a special inbuilt safety brake that will slow the lift and prevent it from travelling too fast on descent. The unit also comes with a key-switch to prevent unauthorised use by visitors and young children.

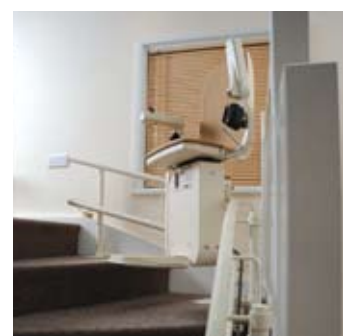



Freedom and Independence

Customer feedback has made it quite clear to us that the biggest benefit to fitting the Platinum Curved Stairlift is it allows the user to remain living in their own home. There are also therapeutic and social benefits in retaining independence at home whilst being amongst family, friends and neighbours.

Using the stairs can be strenuous and quite demanding or in many cases it is impossible. A stairlift can provide a simple, easy and convenient method of getting up and down stairs quickly and safely.

Ease of Use and reliable operation

The Platinum Curved Stairlift is designed to make life easier for you and once fitted it very quickly becomes an invaluable addition to the home. We know that one of the most important things our customers require is ease of operation. We also know reliability is paramount to users and how important it is that a stairlift must be as trouble free as possible. The Platinum Curve was designed to fulfil these requirements.

The easy to use joystick and remote controls ensure the lift is simple to call and run. Each rail is custom built to fit the staircase of our customers' home. We have invested in precision manufacturing processes and machinery in order that each lift is custom-built to superb standards.

The on-board diagnostic system informs and assists with functions and provides operational and service details for easy diagnosis. Powerful batteries ensure that even in the event of a mains power failure the stairlift can operate as normal. The battery management system will only allow the lift to commence a journey if there is sufficient power to complete it.

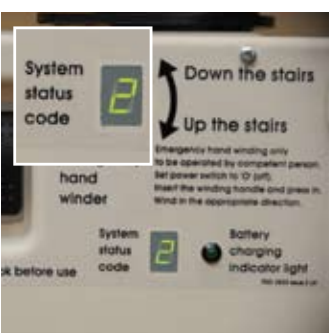

Powered options

The Motorised Swivel Seat This feature automatically rotates the seat at the top of the stairs when you are ready to alight and is perfect for anyone who may have difficulty swivelling the seat around manually

The Automatic Footrest Raiser Allows the footrest to fold up at the touch of a button and is ideal for people who have difficulty bending.



Environment and sustainability

Platinum Stairlifts not only understands the need to supply our customers with high quality, reliable and cost effective products, we are also acutely aware of our responsibility to the environment.

In addition to offering new products, we have a long established reconditioning business, dedicated to refurbishing and recycling stairlifts throughout the UK. By choosing a Platinum stairlift you will not only be taking comfort from receiving an excellent and reliable product, you will be doing your bit to help the environment too.

Built in the UK to exceptional standards

We understand how much reliance many of our customers place in our products. That is why we will not compromise on build quality. The attention to detail and engineering excellence is evident in the Platinum Curve and we only use high quality components and materials. In addition to exceptional manufacturing excellence, every lift must pass numerous quality inspections and meet requisite standards which includes a full test ride before leaving our factory.

Platinum Stairlifts is proud to be a British company and we hope our customers will support our commitment to retaining our factory and manufacturing base here in the UK. Most of the materials used in our manufacturing processes and the components in our products are sourced from British suppliers.

Award winning

In 2009 The Green Organisation awarded its highest accolade, a Green Apple Gold to Platinum Stairlifts. The award was in recognition for outstanding commitment in the field of waste management and manufacturing practice.

The Green Organisation is an independent, non-political, non-profit environment group which is dedicated to recognising, rewarding and promoting environmental best practice around the world. The Green Organisation is supported by the Environment Agency and the Chartered Institute of Environmental Health.





Delivery & installation

Many of our customers need their stairlifts to be supplied as quickly as possible. To this end we have invested in modern manufacturing processes which can deliver our curved lifts within an industry leading 10 days.* To ensure a precision fit your Platinum stairlift will be installed by qualified and trained engineers from our nationwide network of approved retailers and installers.

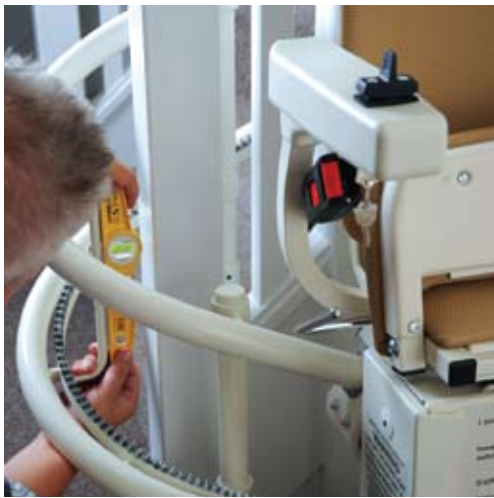

Buy with confidence

All our stairlifts are guaranteed with a minimum 12-month warranty.

Platinum Stairlifts is an active member of the British Healthcare Trades Association (BHTA) an organisation to which membership requires a strict adherence to codes of practice and a commitment to high levels of quality and customer service.

At Platinum, all our customers are special and each order receives the same level of dedication and attention one expects from a first-class company.



* Dependent upon specification and survey

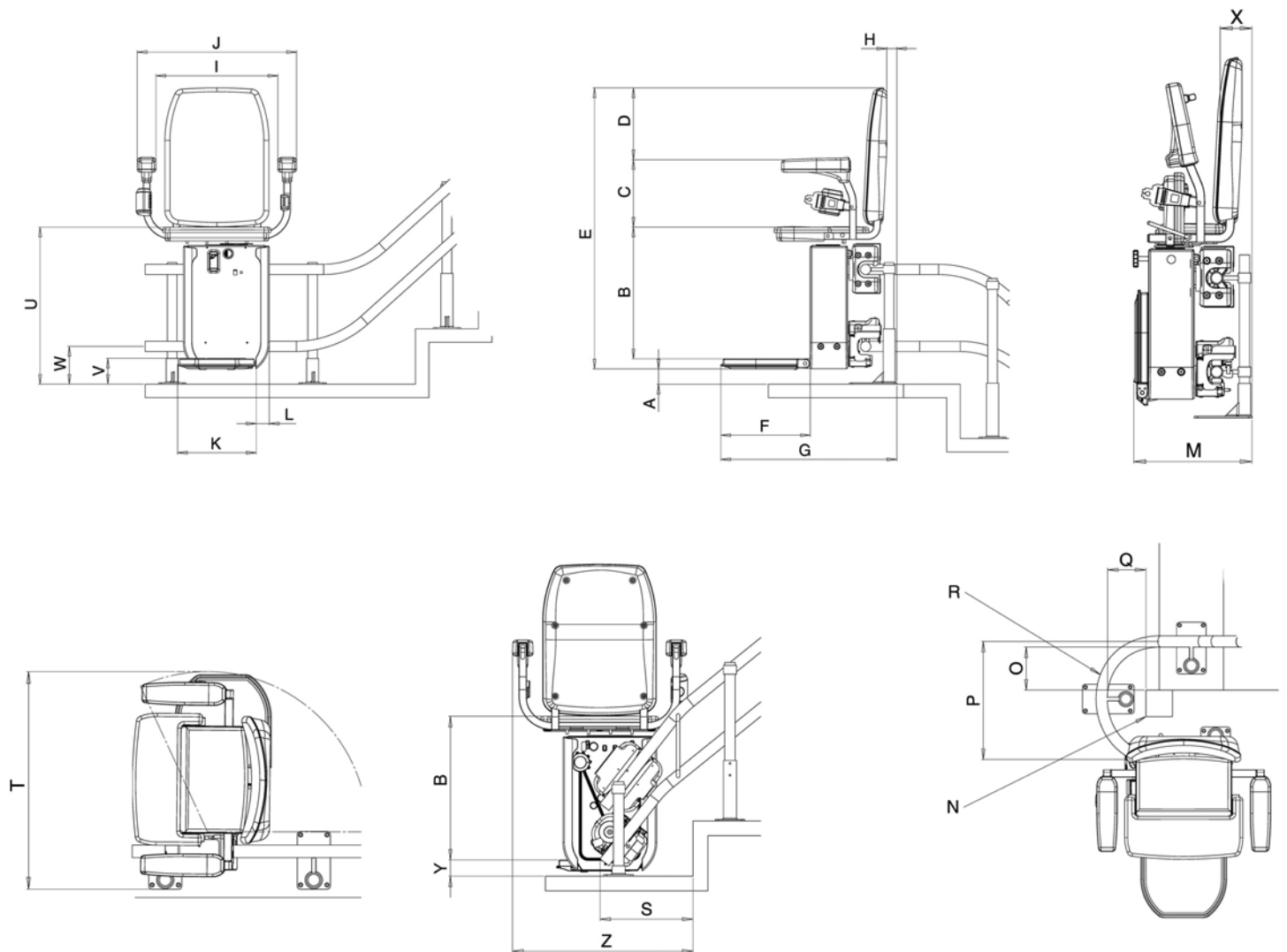

Platinum Curve		mm	inches
A	Floor to bottom of footrest	54	2.1
B	Top of footrest to top of seat	494	19.4
C	Top of seat to top of arms	244	9.6
D	Top of arms to top of seat back	261	10.3
E	Overall height	1041	41.0
F	Length of footrest	329	13.0
G	Front of footrest to back of leg	65.1	25.6
H	Back of seat to back of leg	39	1.5
I	Width between armrests	541	21.3
J	Overall width	589	23.2
K	Width of footrest	290	11.4
L	Footrest offset	49	1.9
M	Folded footrest width	363	14.3
N	Newel post typical	90x90	3.5x3.5
O	Newel post to inside of rail	136	5.4
P	180 Bend on rail centre to centre typical	400	15.7
Q	Newel post to inside of rail	136	5.4
R	Bend radius on centre line (min)	200	7.9
S	Front of drop nose to first step (typical* 52 start)	300	11.8
T	Minimum swivel radius from wall	660	26.0
U	Seat to floor (on a horizontal run on)	589	23.2
V	Top of the footrest to floor (on a horizontal run on)	95	3.7
W	Centre of the tube to floor	140	5.5
X	Back of chain (inside) to wall (on a horizontal run on)	115	4.5
Y	Top of the footrest to floor (on normal start)	58	2.0
Z	Armrest to 1st riser (on typical* 52 start)	610	21.0

Technical Data Sheet



*Typical step: 180mm height

Measurements are only a guide and subject to site and client survey

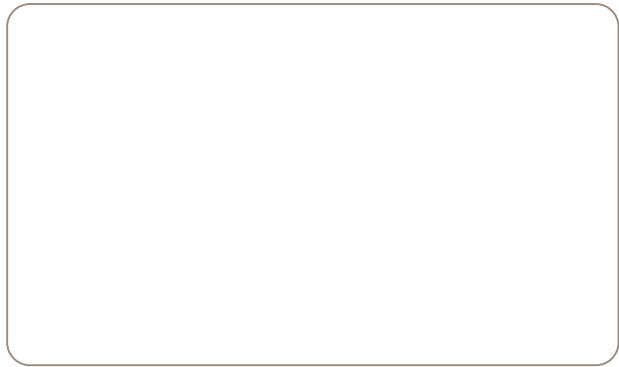

Contact your nearest retailer and find out how a Platinum Stairlift could improve your lifestyle:



The Natural Choice

This brochure is printed on Revive 75 Recycled 225gsm silk art.

Designed by Gravitas Marketing Consultancy Tel. 0191 522 5568 www.gravitasmarketing.co.uk